

24V Input Connection

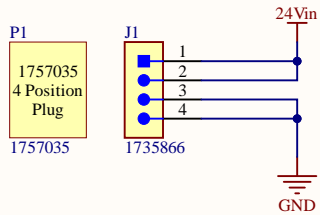

Input power details:

- Cell Type: 2 X LiFePO4 in series
- Nominal Voltage: 25.6V
- Capacity: 100 Ah
- Max Current: 100 A
- Internal BMS with circuit protection
- M8 connection terminals

24V Protection Circuitry

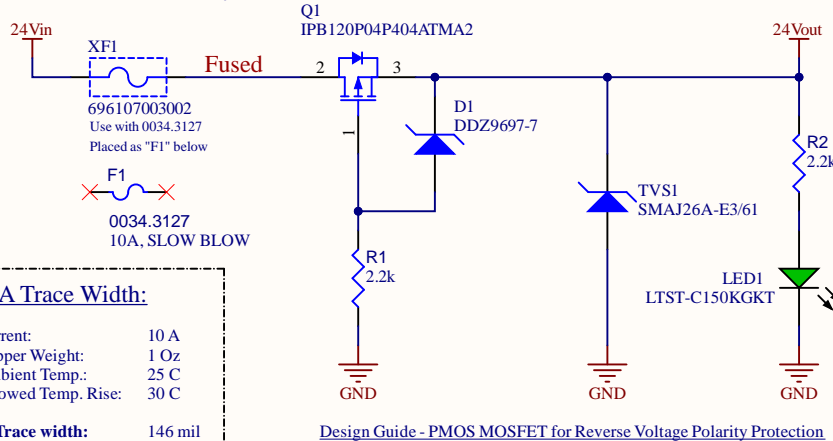

10A Trace Width:

Current: 10 A
Copper Weight: 1 Oz
Ambient Temp.: 25 C
Allowed Temp. Rise: 30 C

Trace width: 146 mil

Design Guide - PMOS MOSFET for Reverse Voltage Polarity Protection

24V Output Connection

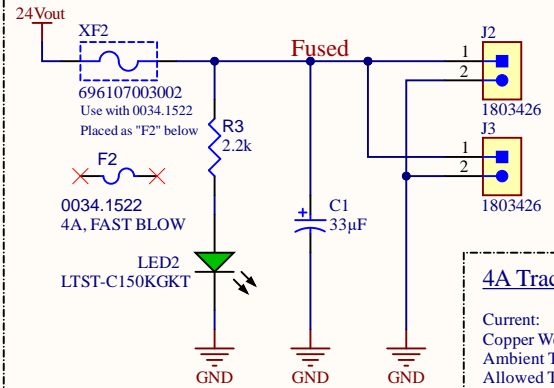

4A Trace Width:

Current: 4 A
Copper Weight: 1 Oz
Ambient Temp.: 25 C
Allowed Temp. Rise: 20 C

Trace width: 53 mil

Capacitor selection guide

12V Switching Power Supply

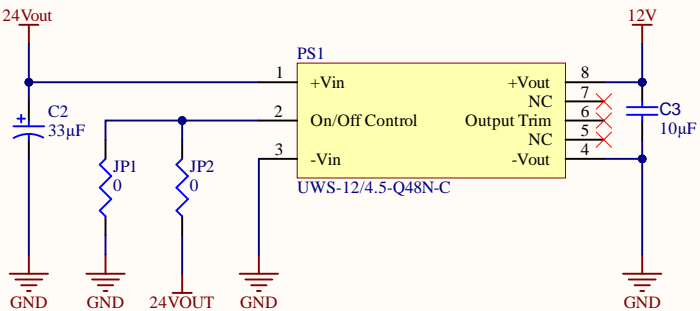

5V Switching Power Supply

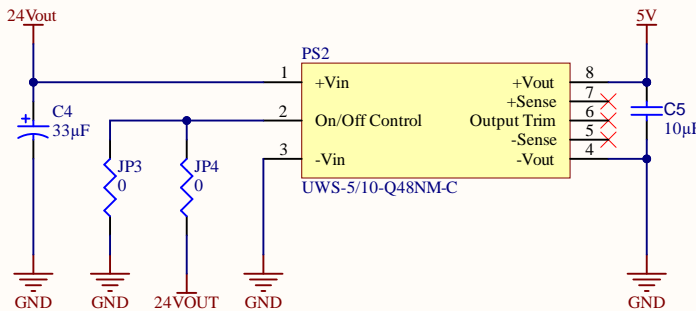

3.3V LDO Regulator Power Supply

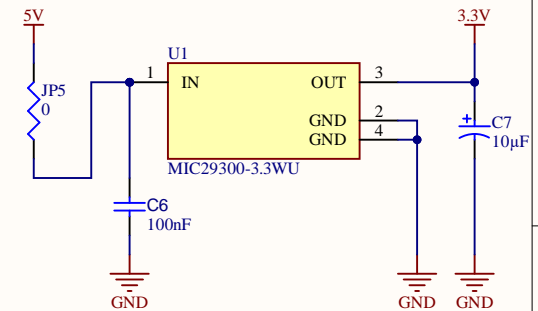

12V Output Connector and Protection

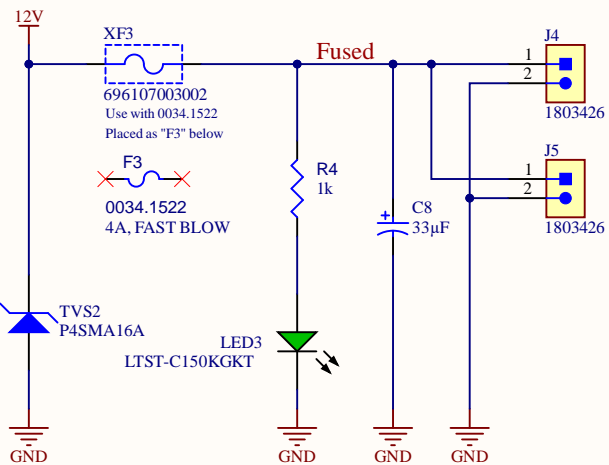

All board headers placed with matching plugs. Every J has a corresponding P.

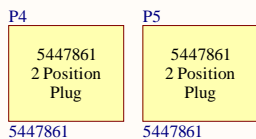

5V Output Connectors and Protection

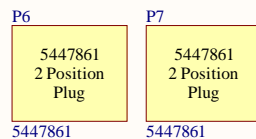
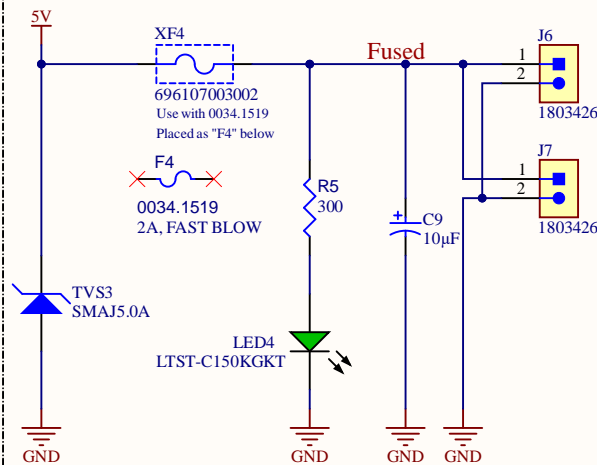

3.3V Output Connector and Protection

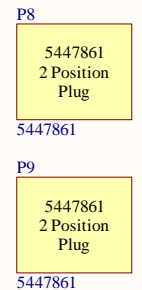
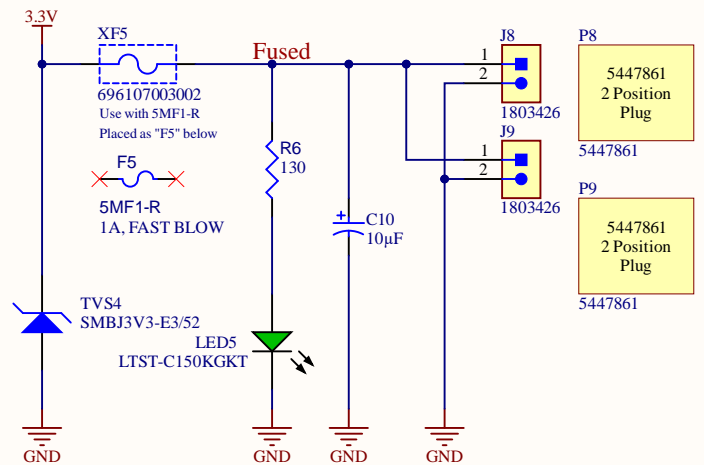

Title **ZAAPP Power Distribution Board**

Team F
MRSD
16-681

Size: Letter Number: 1 Revision: A
Date: 4/5/2024 Time: 4:07:15 AM Sheet 1 of 2
File: Sheet1.SchDoc



Spare parts:

Input Connector:

SparePart1

1757035
4 Position
Plug

1757035

Output Connector:

SparePart2

5447861
2 Position
Plug

5447861

Fuses:

SparePart3

 0034.3127
10A, SLOW BLOW

SparePart4

 0034.3127
10A, SLOW BLOW

SparePart5

 0034.1522
4A, FAST BLOW

SparePart6

 0034.1522
4A, FAST BLOW

SparePart7

 0034.1519
2A, FAST BLOW

SparePart8

 0034.1519
2A, FAST BLOW

SparePart9

 5MF1-R
1A, FAST BLOW

SparePart10

 5MF1-R
1A, FAST BLOW

Hardware:

M1

Hex Stand-off
M3, 9mm

CBTS030A

M2

Hex Stand-off
M3, 9mm

CBTS030A

M3

Hex Stand-off
M3, 9mm

CBTS030A

M4

Hex Stand-off
M3, 9mm

CBTS030A

M5

Screw
M3 X 6 mm
Nylon

97790603111

M6

Screw
M3 X 6 mm
Nylon

97790603111

M7

Screw
M3 X 6 mm
Nylon

97790603111

M8

Screw
M3 X 6 mm
Nylon

97790603111

Title **ZAAPP Power Distribution Board**

Team F
MRSD
16-681

Size: Letter Number: 1 Revision: A

Date: 4/5/2024 Time: 4:07:16 AM Sheet 2 of 2

File: Sheet2.SchDoc

